

RAVEN MAX: Safety advice bottom bracket sleeve

DANGER!

Always use a proper bottom bracket (B/B) sleeve. Otherwise there is a high risk of serious injury or death. The sleeve should run through the B/B shell from left to right without interruption. The sleeve needs to be made from stiff, strong material (e.g. original SRAM PF30 sleeve or aluminum material) to withstand the RD shift cable's tension. The min. outer diameter of the sleeve needs to be 40 mm, the maximal outer diameter of the sleeve cannot be larger than 44 mm, close to the pressfit zone (8-10 mm width). If a soft sleeve is used, there is high risk of damaging both liner and then soft sleeve and B/B axle (s. fig.).

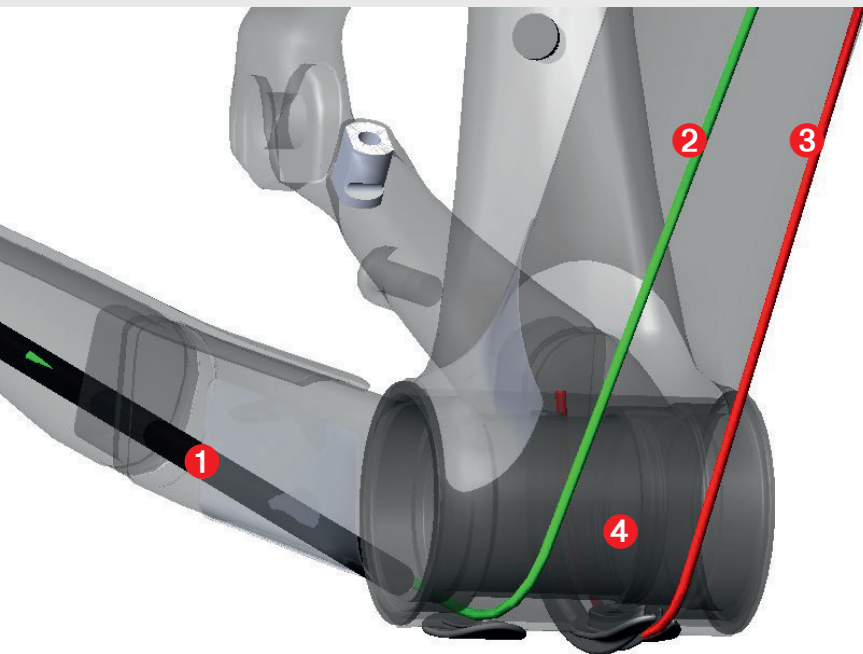

1. RD CS LINER (DCW = 325915032)
2. RD LINER [DCW = 325916105; REACHES HALFWAY INTO RD CS LINER (DCW = 325915032)]
3. FD LINER (DCW = 325916105; ENDS IN FD GUIDE)
4. P30 SLEEVE

RAVEN MAX - LINER ASSEMBLY